



## ORNATE GARDEN

A garden should be enjoyed so make it somewhere to relax and unwind from dining to lounging, study to sleep, to entertain or a garden retreat



# THE WHEEL BENCH

This unique shaped bench offers you plenty of shade and shelter. It is ideally designed to be placed against a wall, fence or as a stand-alone picnic bench. This means that this specially shaped seat can fit into many different alcoves of space in your garden when the available space in your garden might be a crucial factor.

## KEY FACTS

- : Stainless steel roof to offer shade and reflect heat
- : Four laminated treated sustainable spruce timber arcs
- : Luxurious water-resistant interior
- : Seating capacity for up to six guests
- : Fitted with removable table top
- : A foot print of no more than a standard garden patio set

Height: 218cm  
Width: 220cm  
Depth: 135cm  
Base area: 170cm x 135cm

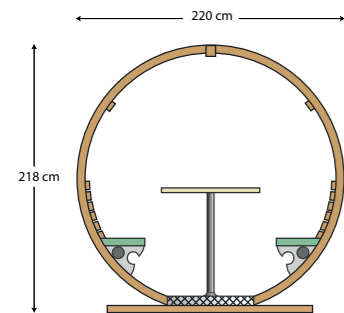

## Installation

An area of 230cm x 145cm is required for the Wheel Bench to be installed. A hard base of no less than 175cm x 140cm is preferred to build your bench onto. The Wheel Bench should be installed onto an area of flat level ground.

## Ground Preparation

If you are preparing new concrete or paving area for your Wheel Bench, we recommend an overall depth of 30cm allowing 7 days for the ground to settle prior to the arrival of our fitting team.



# THE ROTATING SEATER

- : Rotate 360° into the sun, shade or out of the breeze
- : Stainless steel roof to offer shade and reflect heat
- : Six laminated treated sustainable spruce timber arcs
- : Luxurious water resistant interior
- : Front canopy provided for use in all seasons
- : Ambient interior lighting
- : A foot print of no more than a standard garden patio set
- : Option; Can be upgraded to transform into a bed
- : Seating capacity for up to seven guests

Height: 220cm  
Width: 236cm  
Depth: 236cm  
Base area diameter: 140cm x 140cm

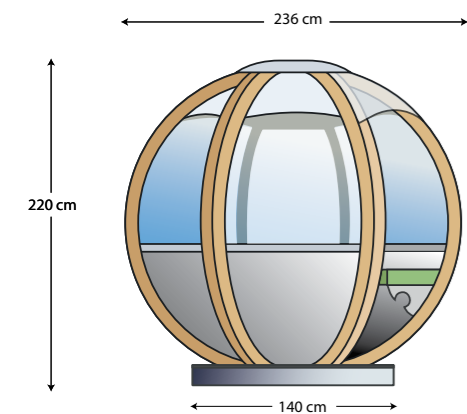

## Installation

An area of 246cm x 246cm is required for the Rotating Seater to rotate freely. A hard standing base of no less than 140cm x 140cm is required to build your Rotating Seater onto. Your sphere can be installed onto a level paved, concrete or decked area. If you are preparing a new concrete or paving area for your Rotating Seater, we recommend an overall depth of 30cm allowing 7 days for the ground to settle prior to the arrival of our fitting team.



# THE ROTATING LOUNGER

- : Rotate 360° into the sun, shade or out of the breeze
- : Lower table to transform into a bed
- : A stainless steel exterior reflects heat and mirrors its surroundings
- : Ten laminated treated sustainable spruce timber arcs
- : Luxurious vinyl water resistant interior
- : Front canopy provided for use in all seasons
- : Ambient interior lighting
- : A foot print of no more than a standard garden patio set
- : Seating capacity for up to eight guests

Height: 250cm  
Width: 244cm  
Depth: 244cm  
Base area diameter: 140cm x 140cm

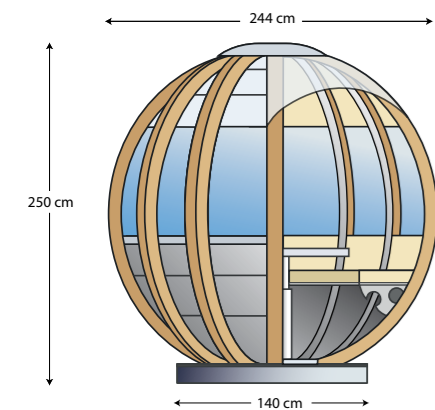

## Installation

An area of 254cm x 254cm is required for the Rotating Lounger to rotate freely. A hard standing base of no less than 140cm x 140cm is required to build your Rotating Lounger onto. Your sphere can be installed onto a level paved, concrete or decked area. If you are preparing a new concrete or paving area for your Rotating Lounger, we recommend an overall depth of 30cm allowing 7 days for the ground to settle prior to the arrival of our fitting team.



# THE OVALHOUSE

- : 360° panoramic views
- : 60cm slide up and over polycarbonate door and rear window
- : A stainless-steel roof to offer shade and reflect heat
- : Eight laminated treated sustainable spruce timber arcs
- : Two sofas provide seating for up to eight guests
- : Luxurious vinyl water resistant interior
- : Ambient interior LED lighting, power facility & heating
- : Power facility and heating
- : Option; Available upgraded option of half bed-mode function

Height: 220cm  
Width: 290cm  
Depth: 240cm  
Base area: 205cm x 140cm

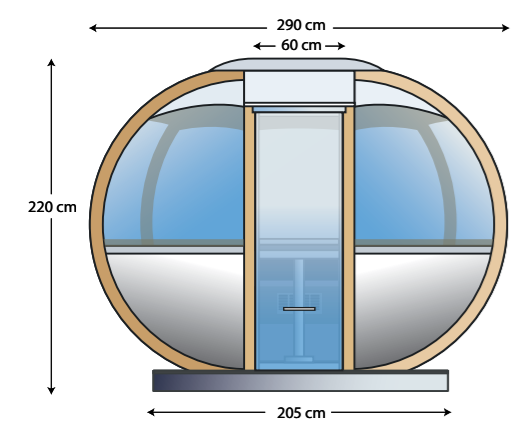

**Installation**  
An area of 300cm x 250cm is required to locate the Ovalhouse. A hard-standing base of no less than 215cm x 145cm is required to build your Ovalhouse onto. Your Ovalhouse can be installed onto a level paved, concrete or decked area. If you are preparing a new concrete or paving area for your Ovalhouse, we recommend an overall depth of 30cm allowing 7 days for the ground to settle prior to the arrival of our fitting team.



# THE MEDIUM OVALHOUSE

- : 360° panoramic views
- : Lockable French door entrance
- : 100cm slide up and over polycarbonate rear window
- : A stainless-steel roof to offer shade and reflect heat
- : Eight laminated treated sustainable spruce timber arcs
- : Two sofas provide seating for up to eight guests
- : Luxurious vinyl water resistant interior
- : Ambient interior LED lighting
- : Power, heating and Bluetooth audio connection

Height: 220cm  
Width: 330cm  
Depth: 250cm  
Base area: 250cm x 175cm

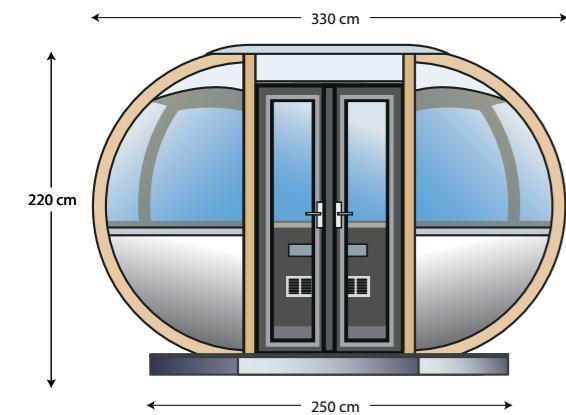

## Installation

An area of 340cm x 250cm is required to locate the Medium Ovalhouse. A hard-standing base of no less than 250cm x 175cm is required to build your Medium Ovalhouse onto. Your Medium Ovalhouse can be installed onto a level paved, concrete or decked area. If you are preparing a new concrete or paving area for your Medium Ovalhouse, we recommend an overall depth of 30cm allowing 7 days for the ground to settle prior to the arrival of our fitting team.



# THE OFFSET OVALHOUSE

- : A stainless steel exterior to offer shade and reflect heat
- : Lockable French door entrance
- : Ten laminated, treated, sustainable spruce timber arcs
- : Three slide up and over polycarbonate windows
- : Two sofa areas provide seating for up to ten guests
- : Luxurious vinyl water resistant interior
- : Ambient interior LED lighting
- : Option; Can be upgraded with additional office table top
- : Option; Can be upgraded to have a half bed-mode
- : Power, heating & Bluetooth audio connection

Height: 220cm  
Width: 390cm  
Depth: 236cm  
Base area: 320cm x 175cm

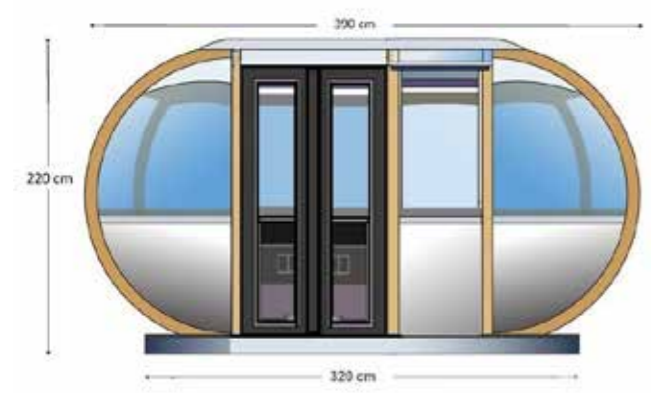

## Installation

An area of 400cm by 250cm is required for The Offset Ovalhouse. A hard standing base of no less than 330cm by 175cm is required to build your pod onto. Your building can be installed onto a level paved, concrete or decked area. If you are preparing a new concrete or paving area for your Offset Ovalhouse, we recommend an overall depth of 30cm allowing seven days for the ground to settle prior to the arrival of our fitting team.



# THE LARGE OVALHOUSE

- : Stainless steel roof to offer shade and reflect heat.
- : Twelve laminated, treated, sustainable spruce timber arcs
- : Lockable French door entrance
- : Five Slide up and over polycarbonate windows
- : Two luxurious water resistant seating areas for up to fourteen guests
- : Two separate table tops to entertain up to fourteen guests
- : Ambient interior LED lighting
- : Heated for all year round use
- : Electrical power and Bluetooth facility
- : Includes UK mainland delivery and installation.

Height: 220cm  
Width: 460cm  
Depth: 240cm  
Base area: 360cm x 175cm

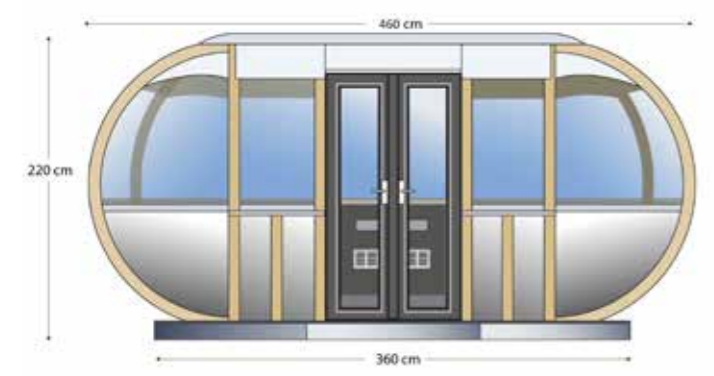

**Installation**  
An area of 470cm x 250cm is required to locate The Large Ovalhouse. A hard standing base of no less than 365cm x 175cm is required to build your pod onto. Your building can be installed onto a level paved, concrete or decked. If you are preparing a new concrete or paving area for your Large Ovalhouse, we recommend an overall depth of 30cm allowing 7 days for the ground to settle prior to the arrival of our fitting team



# EXTRA LARGE OVALHOUSE

- : Stainless steel roof offering shade and reflect heat.
- : Sixteen laminated, treated, sustainable spruce timber arcs
- : Lockable French door entrance
- : Four Slide up and over polycarbonate windows
- : Two seating areas for up to twenty guests
- : Two separate dining table areas
- : Ambient interior, coloured mood and LED down lighting
- : Temperature Control Thermostat (2.4 Kw Blow Hot 'or' Cold air)
- : Electrical power socket
- : Bluetooth Sound Bar

Height: 220cm  
Width: 740cm  
Depth 236cm  
Base area: 650cm x 175cm

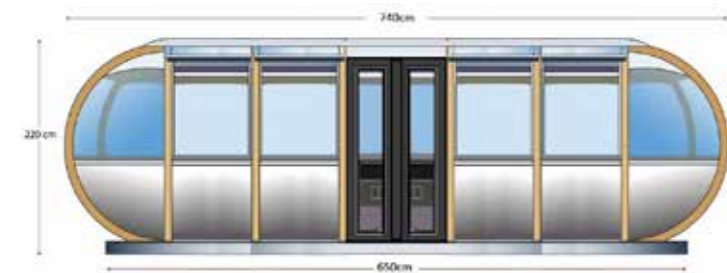

## Installation

To accommodate the Extra Large Ovalhouse, a clear area of 750cm x 250cm is required. The structure must be installed onto a hard-standing base measuring at least 650cm x 175cm. Suitable base types include level paving, concrete, or decking.

If you are preparing a new concrete or paved base, we recommend a minimum depth of 30cm. Please allow 7 days for the ground to settle before installation.



# OVALHOUSE BAR

- : Lockable French door entrance
- : Three Slide up and over polycarbonate windows
- : Luxurious seating areas for up to fourteen guests
- : Three separate tabletops for entertaining
- : Bar serving and cupboard storage areas
- : Bar optics with spirits measure bar
- : Beer fridge, bottle cooler with glass door
- : Ambient interior LED lighting, 24v Bluetooth Sound Bar
- : Temperature Control Thermostat (2.4 Kw Blow Hot 'or' Cold air)
- : Power points + 2 USB Ports

Height: 220cm  
Width: 540cm  
Depth 236cm  
Base area: 475cm x 218cm  
Doorstep Width: 120cm, French Door Width: 100cm



## Installation

To position your Ovalhouse Bar Pod, a clear area of 550cm x 250cm is required. The structure must be installed onto a hard-standing base measuring at least 480cm x 175cm. Suitable surfaces include level paving, concrete, or decking.

If you are preparing a new concrete or paved base, we recommend a minimum depth of 30cm, allowing the ground to settle for at least 7 days prior to installation.



# THE SUMMERHOUSE

- : 60cm slide up and over polycarbonate door and two side windows
- : A stainless steel roof to offer shade and reflect heat
- : Twelve laminated treated sustainable spruce timber arcs
- : Two sofas provide seating for up to ten guests
- : Easy clean interior, stain and mould resistant
- : Ambient interior LED lighting
- : Power, heating and Bluetooth audio connection

Height: 230cm  
Width: 278cm  
Depth: 278cm  
Base area diameter: 190cm x 190cm

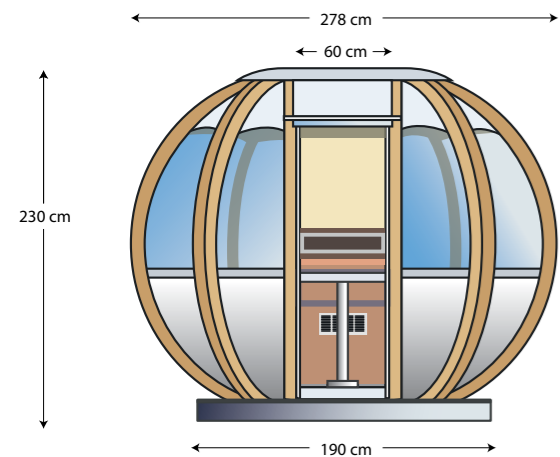

## Installation

An area of 288cm x 288cm is required to locate the Summerhouse. A hard-standing base of no less than 195cm x 195cm is required to build your Summerhouse onto. Can be installed onto a level paved, concrete or decked area. If you are preparing a new concrete or paving area for your Summerhouse, we recommend an overall depth of 30cm allowing 7 days for the ground to settle prior to the arrival of our fitting team.



# MEDIUM SUMMERHOUSE

- : 80cm Lockable double-glazed single door entrance
- : Two 80cm slide up and over polycarbonate side windows
- : A stainless-steel roof to offer shade and reflect heat
- : Twelve laminated treated sustainable spruce timber arcs
- : Two sofas provide seating for up to ten guests
- : Option; Can be upgraded to include removeable office table top
- : Easy clean interior, stain and mould resistant
- : Ambient interior LED lighting
- : Power, heating and Bluetooth audio connection
- : Option; Office desk top upgrade

Height: 230cm

Width: 298cm

Depth: 298cm

Base area: 200cm x 225cm

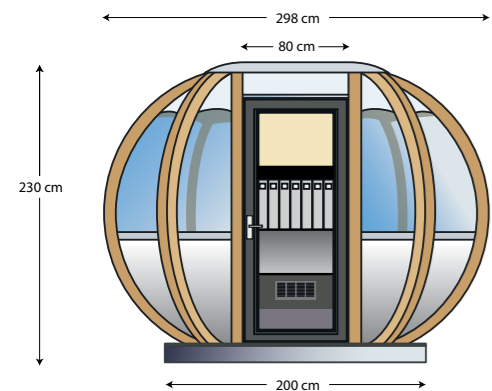

## Installation

An area of 308cm x 308cm is required to locate the Medium Summerhouse. A hard-standing base of no less than 200cm x 225cm is required to build your Medium Summerhouse onto. Can be installed onto a level paved, concrete or decked area. If you are preparing a new concrete or paving area for your Medium Summerhouse, we recommend an overall depth of 30cm allowing 7 days for the ground to settle prior to the arrival of our fitting team.



# THE DELUXE

- : Create your own interior with the help of our design team
- : 60cm slide up and over polycarbonate door and two side windows
- : A stainless steel exterior reflects heat and mirrors its surroundings
- : Sixteen laminated treated sustainable spruce timber arcs
- : Two sofas provide seating for up to ten guests
- : Easy clean interior, stain and mould resistant
- : Ambient interior LED lighting
- : Power, heating and Bluetooth audio connection

Height: 260cm  
Width: 300cm  
Depth: 300cm  
Base area: 200cm x 200cm

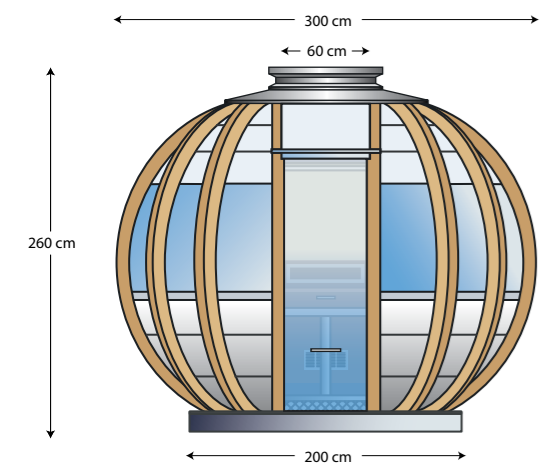

## Installation

An area of 310cm x 310cm is required to locate the Deluxe. A hard-standing base of no less than 200cm x 200cm is required to build your Deluxe onto. Can be installed onto a level paved, concrete or decked area. If you are preparing a new concrete or paving area for your Deluxe, we recommend an overall depth of 30cm allowing 7 days for the ground to settle prior to the arrival of our fitting team.



# THE GRANDE DELUXE

- : Create your own interior with the help of our design team
- : 100cm slide up and over polycarbonate door and two side windows
- : A stainless steel exterior reflects heat and mirrors its surroundings
- : Sixteen laminated treated sustainable spruce timber arcs
- : Two sofas provide seating for up to twelve guests
- : Easy clean interior, stain and mould resistant
- : Ambient interior LED lighting
- : Power, heating and Bluetooth audio connection

Height: 260cm  
Width: 334cm  
Depth: 335cm  
Base area: 250cm x 250cm

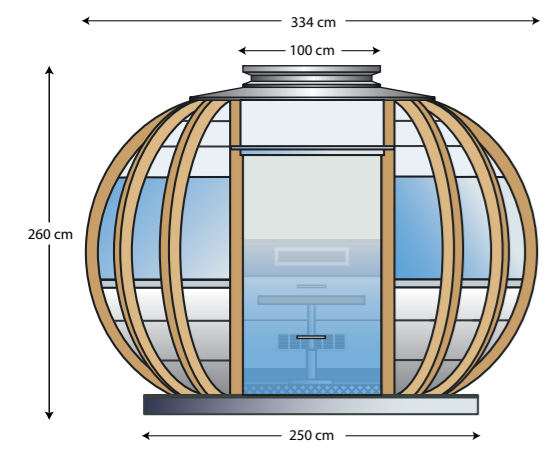

## Installation

An area of 345cm x 345cm is required to locate the Grande Deluxe. A hard standing base of no less than 255cm by 255cm is required to build your Grande Deluxe onto. Your building can be installed onto a level paved, concrete or decked area. If you are preparing a new concrete or paving area for your Grande Deluxe, we recommend an overall depth of 30cm allowing 7 days for the ground to settle prior to the arrival of our fitting team.



# THE GRANDE DELUXE CHIC

- : Stainless steel roof to offer shade and reflect heat.
- : Sixteen laminated, treated, sustainable spruce timber arcs
- : Lockable French door entrance
- : Two Slide up and over polycarbonate windows
- : Two sofas provide seating for up to twelve guests
- : Easy clean interior, stain and mould resistant
- : Ambient interior LED lighting
- : Heating for all year-round use
- : Electrical power and Bluetooth facility
- : Includes UK mainland delivery and installation

Height: 260cm  
Width: 334cm  
Depth: 335cm  
Base area: 250cm x 270cm

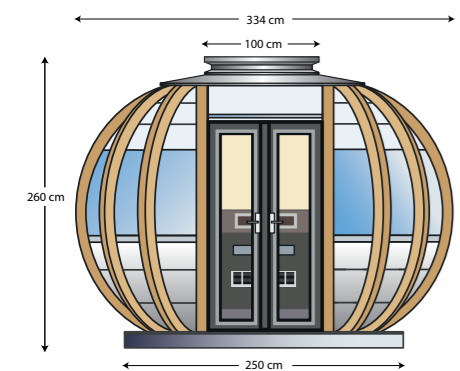

**Installation**  
An area of 345cm x 345cm is required to locate the Grande Deluxe Chic. A hard standing base of no less than 255cm by 275cm is required to build your Grande Deluxe Chic onto. Your building can be installed onto a level paved, concrete or decked area. If you are preparing a new concrete or paving area for your Grande Deluxe, we recommend an overall depth of 30cm allowing 7 days for the ground to settle prior to the arrival of our fitting team



# THE DELUXE SUPREME

- : Lockable Double Glazed single door entrance
- : Four Slide up and over polycarbonate windows
- : Gas-assisted height adjustable dining table & fixed pedestal table
- : Two sofa areas provide seating for up to twelve guests
- : Storage cupboard
- : Easy clean interior, stain and mould resistant
- : Ambient interior, coloured mood and LED down lighting
- : Temperature Control Thermostat (2.4 Kw Blow Hot 'or' Cold air)
- : 24v Bluetooth Audio Sound Bar, 13amp Power Socket
- : Includes UK mainland delivery and installation

Height: 260cm

Width: 402cm

Depth: 313cm

Base area: 320cm x 180cm

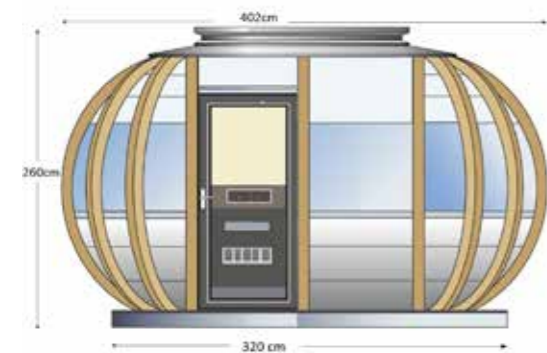

## Installation

To position your Deluxe Supreme, a clear area of 320cm x 180cm is required. The structure must be installed onto a hard-standing base measuring at least 275cm x 225cm. Suitable base types include level paving, concrete, or decking.

If you are preparing a new concrete or paved base, we recommend a minimum depth of 30cm, allowing the ground to settle for at least 7 days before installation.



# OUR COMMERCIAL PROJECTS

From practical to contemporary, our pod structures are design to suit the demand of...



Hotels



Restaurants & Cafes



Business Parks



Golf Clubs



Public Gardens



Sports Clubs



Community Centres



Meeting Spaces



Manufacturing Premises



Education



Government



Ski Resorts



Holiday Parks



Glamping Resorts



Care Homes



Our garden buildings are recognised by leading commercial enterprises around the world for their high quality and unique design





## Inspired for life

We understand the ever-increasing implications of excessive Carbon Footprints and the urgent need to only use timber components that are from well managed sustainable sources.

Ornate Garden are proud to continue to manufacture our products, with a consideration to using component parts sourced locally. A high percentage of our component parts are sourced within a fifty mile radius of our manufacturing premises, to ensure we continue to maintain a low level Carbon footprint.

Ornate Garden use only well maintained, sustainably sourced, plantation timber to manufacture our beautiful garden buildings.

## Thinking of you

*from design, to installation and beyond*

We are committed to delivering an excellent service. Our experienced team are on hand to answer any questions and help guide you through our pod collection, whether it's a view to dine, a sanctuary for lounging or room to study, our team will help perfectly tailor a pod to match your lifestyle.

We look beyond the installation to ensure that you're completely happy with your new pod, guiding you through all the features and making sure that you're happy with any care and maintenance.

## Delivery 🚚✂️

Ornate Garden provide a 'dedicated' delivery & installations service. After we arrange delivery, our fitting team will build your pod in your area of preference, removing any packaging leaving you 'Fully Assembled' and 'Ready to Use'

We delivery & install pods to countries worldwide...

## Let's be social



facebook.com/OrnateGarden



twitter.com/ornategarden



instagram.com/ornategardenpods



pinterest.co.uk/OrnateGarden

\*All pods (buildings) are subject to upgrades and additional alterations to coincide with any upgrades.

## What our customers say

*Fantastic buy. Best ever garden feature. Use it every day*  
**Linda Johnson**

*Best thing I've ever bought. Were in it all the time. Everyone loves the pod, Champagne at New Year. Little princesses on birthday. Great!*  
**David Littlefair**

*Had ours for six years, just great and always admired. Others have bought one after sharing lovely evenings.*  
**Bob and Linda Simpson**

*The pod has been a total success. Its so comfortable in all weathers. A great talking point with visitors*  
**Sela Mooney**

*It has been the best value we have ever had. We love it and call it our Peace Pod. Thankyou very much.*  
**Pam and Ron Ellis**

## How to find us

You are always welcome to visit our showroom near Coleshill in the Midlands to view our range of garden pods. Exit either the M6 at junction 4 or the M42 at Junction 6 and head to Coleshill crossroads, follow the B4114 to Shustoke. Turn right onto Castle lane before entering Shustoke.

## Visit Us

Mon - Thurs: 8.30 - 5.00pm  
Fri 8.30 - 3.00pm  
CLOSED BANK HOLIDAYS

If you require opening hours outside our standard hours please call  
+44 (0) 1675 464705





Ornate Garden, Castle Lane, Maxstoke, Coleshill, Birmingham. B46 2RA  
e: sales@ornategarden.com t: +44 (0)1675 464 705 w: www.ornategarden.com